

SEAT commons

Furniture built in collaboration by the PEI group of Pontificia Universidad Javeriana de Bogotá, Basurama and Zuloark, during the second edition of Hand Made Urbanismo workshop for Campo de Cebada urban space.

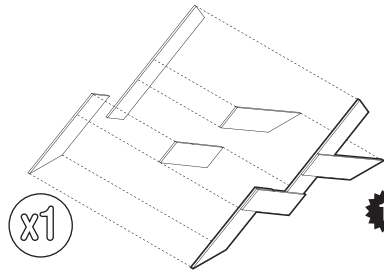

If you are "commons" believer lay down with your partners and discuss it face to face. Easy to build in group and very practical.

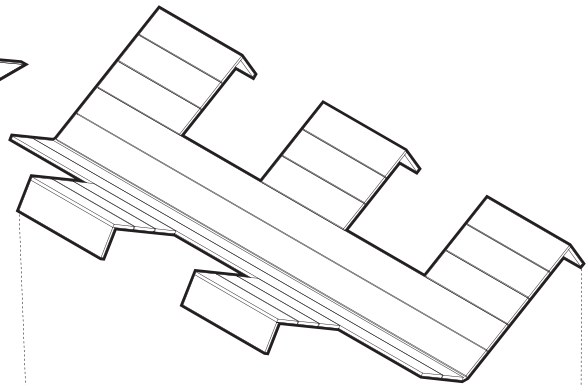
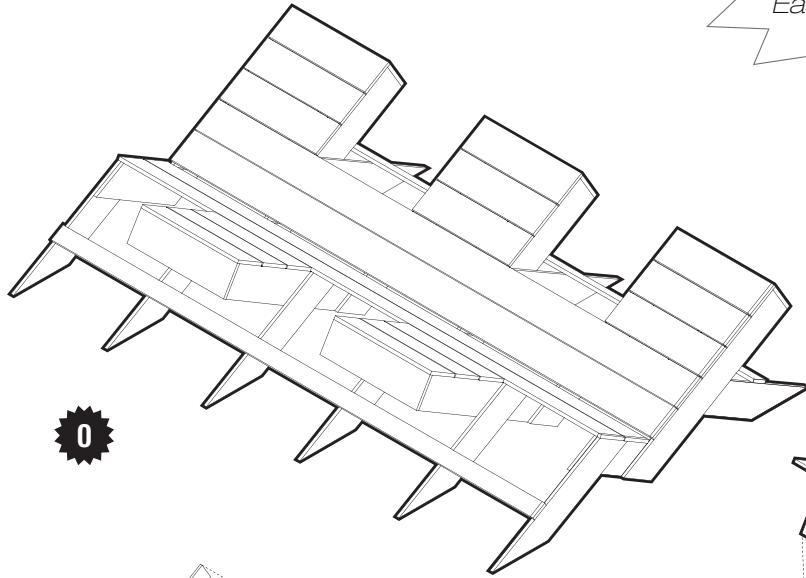

1 Building the ribs.
Assemble the ribs by joining the wooden pieces as shown in image 1. Now repeat the same process but leave one of the legs stick out a bit. Repeat step 1&2 but mirrored.

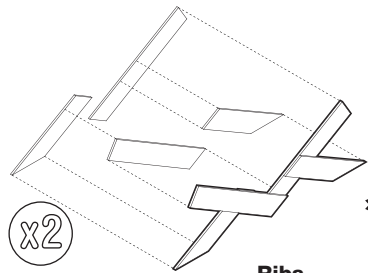

2 Ribs.
with leg sticking out a bit.

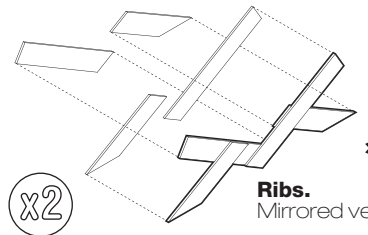

3 Ribs.
Mirrored version of step 2.

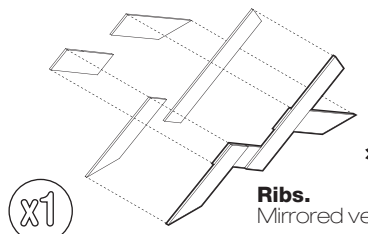

4 Ribs.
Mirrored version of step 1.

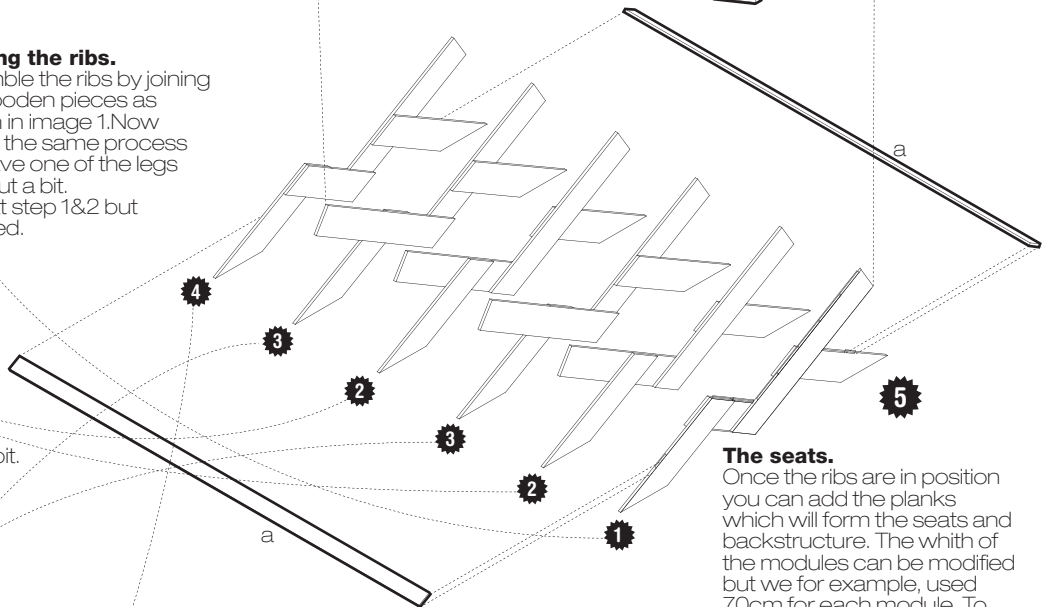

The seats.
Once the ribs are in position you can add the planks which will form the seats and backstructure. The width of the modules can be modified but we for example, used 70cm for each module. To finalize you can add a plank at foot-height (a)

